

WILLIAM

Hydraulic Cone Crusher

WILLIAM

• DIMENSIONS

VS-Type

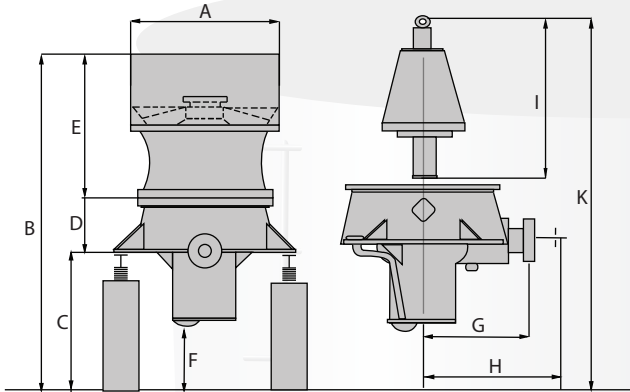

VH-Type

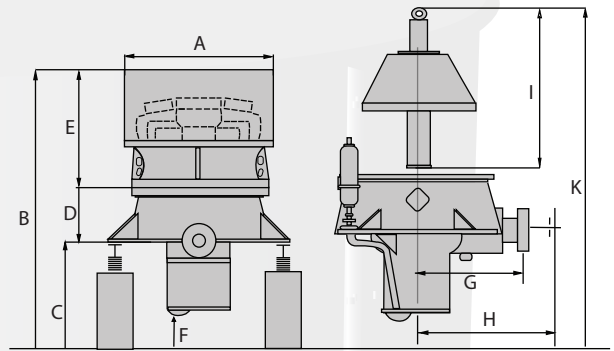

WILLIAM

• APPROXIMATE WEIGHTS

VS-Type

VH-Type

	VS-3000	VS-4000	VH-3000	VH-4000
Heaviest lift during maintenance	5100	8100	3280	5300
Total weight	12000	19300	9580	14900

VS-Type

VH-Type

Dimension (mm)	VS3000	VS4000	VH3000	VH4000
A	1635	2000	1360	1540
B	3485	4075	2992	3410
C	1125	1300	1125	1300
D	655	745	655	745
E	1705	2030	1212	1365
F	422	452	422	452
G	1061	1280	1061	1280
H	1705	1900	1705	1900
I	2050	2420	1688	1985
K	4250	4930	3570	4000

WILLIAM

• Main components and basic concepts

